

Welcome

to



Congratulations

on your

Ownership

of a

Armia
collection

Cot/toddler bed

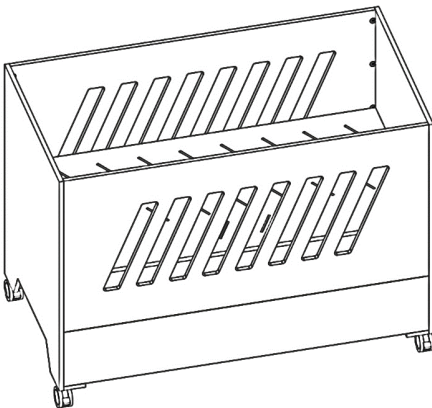

Cot Bed

1360mm(L) x 740mm(W) x 977mm(H)

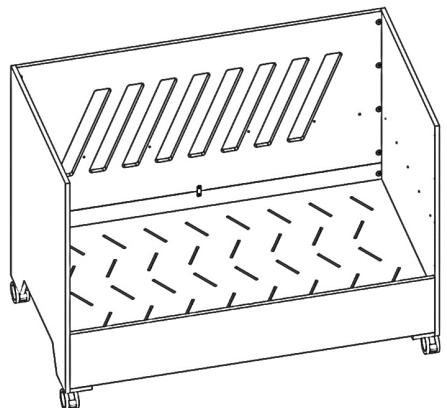

Toddler Bed

1360mm(L) x 740mm(W) x 977mm(H)

Recommended Mattress Size: 1300mm(L) x 690mm(W) x 120mm(H)



WARNING

- Please follow all Manufacturer's Instructions
- Never Leave child unattended
- This assemble will require two people
- Recommend not to use screw gun or impact driver
- Please use a handheld Phillips head screwdriver
- All screws and cams are tightened and then checked after 2 months
- Mattress must not exceed the thickness of 120mm or stacked on top to make higher
- Mattress recommended size of 1300mm long x 690mm wide and 120mm
- When child can stand, please lower bed base to the lower position
- Toddler position please lock all brakes on the castors of the bed or take them off
- Meets Australian Standards AS/NZS 2172:2003
- All stains and finishes are non-toxic and in compliance with AS/NZS:2172 2013.

Furniture Care & Maintenance Guide

- Don't expose furniture to direct sunlight, extreme heat, and changes in temperature
- Don't use strong household cleaner or abrasives products.
- Avoid contact with any hot liquids
- No sharp objects to use on furniture
- When moving furniture unlock brakes on castors
- Baby weight not to excess 25KG
- Best cleaning, please use a damp soft cloth and dry with a soft cloth afterwards
- Any spills wipe immediately with a soft cloth

Please enjoy your furniture for many years to come and let us thank you for purchasing our products.

Warranty:



Kids Home Fashion Pty Ltd Australia warrants the original purchaser of Kids Home Fashion Pty Ltd Furniture against manufacturing defects for as long as the original purchaser owns the product.

This limited 5 Years warranty applies to all Furniture sold by Kids Home Fashion Pty Ltd. This warranty is limited to consumers of our products who register their products or have proof of purchase.

Our goods come with guarantees that cannot be excluded under the Australian Consumer Law. You are entitled to a replacement or refund for a major failure and for compensation for any other foreseeable loss or damage. You are entitled to have goods repaired or replaced if the goods fail to be of acceptable quality and the failure does not amount to a major failure. The benefits provided to the purchaser under this warranty are in addition to any other rights or remedies you may have, as a consumer, under any other law which applies to our products.

Kids Home Fashion Pty Ltd will provide replacement products for the faulty hardware and faulty individual components sold by Kids Home Fashion Pty Ltd. If the hardware and faulty individual components is faulty, Kids Home Fashion Pty Ltd will send the original purchaser replacement hardware and faulty individual components. Kids Home Fashion Pty Ltd does not warrant products which have been incorrectly assembled, exposed to loads more than specifications, abused, or used for purposes other than that for which they are intended. Kids Home Fashion Pty Ltd will not be liable for any consequential or incidental damages resulting from or contributed to by the use, installation, performance, or failure of our products.

To make a claim, contact Kids Home Fashion Pty Ltd Customer Service on email info@kidshomefashion.com. Our customer service team will require proof of purchase (typically this will be a receipt) and evidence of the fault (for example, a photo of the fault of the relevant product).

Congratulations once again on your new Baby Furniture. We hope it meets your expectations and is a place where you create great memories with child. We appreciate that Kids Home Fashion Pty Ltd products has been included in this instance and hope that your experience using it will lead you to decide to select Kids Home Fashion in any future children. To register your Kids Home Fashion Pty Ltd products please visit www.kidshomefashion.com

Note: The advantages of PVC Foam Board which your product is made from:



DURABLE



FIRE RESISTANCE



TERMITE-FREE



WATER RESISTANCE



Kids Home Fashion P/L | ABN: 65 654 657 539 | Email: info@kidshomefashion.com

This document is a strictly confidential communication to and solely for the use of the recipient and may not be reproduced or circulated without Kids Home Fashion P/L prior written consent.

If you are not the intended recipient, you may not disclose or use the information in this documentation in any way. Products carry Patent and Registered Designs Rights.

Under Australian Provisional Application No. 2022901149, Australian Registered Design No. 202212515 and Australian Registered Design No. 202212516.

www.kidshomefashion.com